

MIT OpenCourseWare
<http://ocw.mit.edu>

2.094 Finite Element Analysis of Solids and Fluids
Spring 2008

For information about citing these materials or our Terms of Use, visit: <http://ocw.mit.edu/terms>.

Lecture 21 - Plates and shells

Prof. K.J. Bathe

MIT OpenCourseWare

Timoshenko beam theory, and Reissner-Mindlin plate theory

For plates, and shells, w , β_x , and β_y as independent variables.

w = displacement of mid-surface, $w(x, y)$

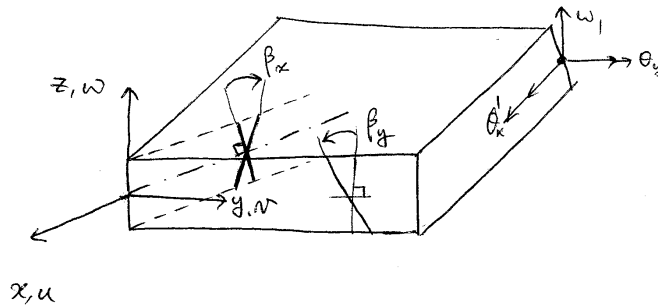

A = area of mid-surface

p = load per unit area on mid-surface

$$w = w(x, y) \quad (21.1)$$

$$w(x, y, z) = w(x, y) \quad (21.2)$$

The material particles at “any z ” move in the z -direction as the mid-surface.

$$u(x, y, z) = -\beta_x z = -\beta_x(x, y)z \quad (21.3)$$

$$v(x, y, z) = -\beta_y z = -\beta_y(x, y)z \quad (21.4)$$

$$\epsilon_{xx} = \frac{\partial u}{\partial x} = -z \frac{\partial \beta_x}{\partial x} \quad (21.5)$$

$$\epsilon_{yy} = \frac{\partial v}{\partial y} = -z \frac{\partial \beta_y}{\partial y} \quad (21.6)$$

$$\gamma_{xy} = \frac{\partial u}{\partial y} + \frac{\partial v}{\partial x} = -z \left(\frac{\partial \beta_x}{\partial y} + \frac{\partial \beta_y}{\partial x} \right) \quad (21.7)$$

$$\begin{pmatrix} \epsilon_{xx} \\ \epsilon_{yy} \\ \gamma_{xy} \end{pmatrix} = -z \underbrace{\begin{pmatrix} \frac{\partial \beta_x}{\partial x} \\ \frac{\partial \beta_y}{\partial y} \\ \frac{\partial \beta_x}{\partial y} + \frac{\partial \beta_y}{\partial x} \end{pmatrix}}_{\kappa} \quad (21.8)$$

$$\gamma_{xz} = \frac{\partial w}{\partial x} + \frac{\partial u}{\partial z} = \frac{\partial w}{\partial x} - \beta_x \quad (21.9)$$

$$\gamma_{yz} = \frac{\partial w}{\partial y} + \frac{\partial v}{\partial z} = \frac{\partial w}{\partial y} - \beta_y \quad (21.10)$$

$$\begin{pmatrix} \tau_{xx} \\ \tau_{yy} \\ \tau_{xy} \end{pmatrix} = \frac{E}{1-\nu^2} \begin{bmatrix} 1 & \nu & 0 \\ \nu & 1 & 0 \\ 0 & 0 & \frac{1-\nu}{2} \end{bmatrix} \begin{pmatrix} \epsilon_{xx} \\ \epsilon_{yy} \\ \gamma_{xy} \end{pmatrix} = \mathbf{C} \cdot \boldsymbol{\epsilon} \quad (21.11)$$

(plane stress)

$$\begin{pmatrix} \tau_{xz} \\ \tau_{yz} \end{pmatrix} = \frac{E}{2(1+\nu)} \begin{pmatrix} \gamma_{xz} \\ \gamma_{yz} \end{pmatrix} = G\boldsymbol{\gamma} \quad (21.12)$$

Principle of virtual work for the plate:

$$\int_A \int_{-\frac{t}{2}}^{+\frac{t}{2}} (\bar{\epsilon}_{xx} \quad \bar{\epsilon}_{yy} \quad \bar{\gamma}_{xy}) \frac{E}{1-\nu^2} \begin{bmatrix} 1 & \nu & 0 \\ \nu & 1 & 0 \\ 0 & 0 & \frac{1-\nu}{2} \end{bmatrix} \begin{pmatrix} \epsilon_{xx} \\ \epsilon_{yy} \\ \gamma_{xy} \end{pmatrix} dz dA + \quad (21.13)$$

$$k \int_A \int_{-\frac{t}{2}}^{+\frac{t}{2}} (\bar{\gamma}_{xz} \quad \bar{\gamma}_{yz}) G \begin{bmatrix} 1 & 0 \\ 0 & 1 \end{bmatrix} \begin{pmatrix} \gamma_{xz} \\ \gamma_{yz} \end{pmatrix} dz dA = \int_A \bar{w} p dA$$

Consider a flat element:

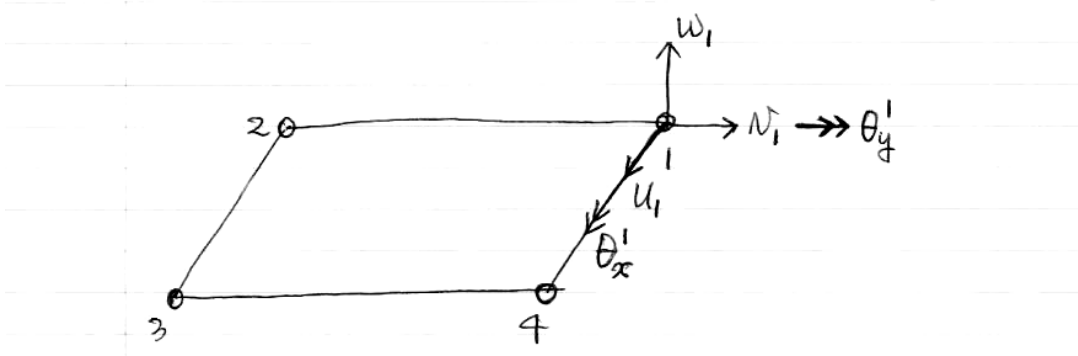

$$\Rightarrow \mathbf{K}_b \begin{pmatrix} w_1 \\ \theta_x^1 \\ \theta_y^1 \\ \vdots \end{pmatrix}, \text{ also } \mathbf{K}_{\text{pl. str.}} \begin{pmatrix} u_1 \\ v_1 \\ \vdots \end{pmatrix} \quad (21.14)$$

where \mathbf{K}_b is 12x12 and $\mathbf{K}_{\text{pl. str.}}$ is 8x8.

For a flat element:

$$\Rightarrow \begin{bmatrix} \mathbf{K}_b & \mathbf{0} \\ \mathbf{0} & \mathbf{K}_{\text{pl. str.}} \end{bmatrix} \begin{pmatrix} w_1 \\ \theta_x^1 \\ \theta_y^1 \\ \vdots \\ \theta_y^4 \\ u_1 \\ v_1 \\ \vdots \\ v_4 \end{pmatrix} = \dots \quad (21.15)$$

$$u = \sum h_i u_i \quad (21.16)$$

$$v = \sum h_i v_i \quad (21.17)$$

$$w = \sum h_i w_i \quad (21.18)$$

$$\beta_x = -\sum h_i \theta_y^i \quad (21.19)$$

$$\beta_y = \sum h_i \theta_x^i \quad (21.20)$$

From (21.13)

$$\int_A \bar{\kappa}^T \frac{Et^3}{12(1-\nu^2)} \begin{bmatrix} 1 & \nu & 0 \\ \nu & 1 & 0 \\ 0 & 0 & \frac{1-\nu}{2} \end{bmatrix} \kappa dA + \int_A \bar{\gamma}^T Gt \cdot k \begin{bmatrix} 1 & 0 \\ 0 & 1 \end{bmatrix} \gamma dA \quad (21.21)$$

where k is the shear correction factor.

Next, evaluate $\frac{\partial w}{\partial x}$, $\frac{\partial w}{\partial y}$, $\frac{\partial \beta_x}{\partial x}$, ... etc. \Rightarrow This element, as it is, locks!

This displacement-based element “locks in shear”. We need to change the transverse shear interpolations.

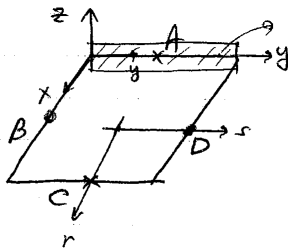

$$\gamma_{yz} = \frac{1}{2}(1-r)\gamma_{yz}^A + \frac{1}{2}(1+r)\gamma_{yz}^C \quad (21.22)$$

where

$$\gamma_{yz}^A = \left(\frac{\partial w}{\partial y} - \beta_y \right) \Big|_{\text{evaluated at A}} \quad (21.23)$$

from the w , β_y displacement interpolations.

$$\gamma_{xz} = \frac{1}{2}(1-s)\gamma_{xz}^B + \frac{1}{2}(1+s)\gamma_{xz}^D \quad (21.24)$$

with this mixed interpolation, the element works. Called MITC interpolation (for **m**ixed **i**nterpolated-**t**ensional components)

Aside: Why not just neglect transverse shears, as in Kirchhoff plate theory?

- If we do, $\gamma_{xz} = \frac{\partial w}{\partial x} - \beta_x = 0 \Rightarrow \beta_x = \frac{\partial w}{\partial x}$
- Therefore we have $\left(\frac{\partial^2 w}{\partial x^2}, \dots\right)$ in strains, so we need continuity also for $\left(\frac{\partial w}{\partial x} \dots\right)$

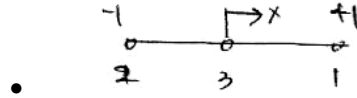

$$w = \frac{1}{2}r(1+r)w_1 - \frac{1}{2}r(1-r)w_2 + (1-r^2)w_3$$

w_2 and w_3 never affect w_1 ($\because w|_{r=1} = w_1$).

But,

$$\frac{\partial w}{\partial r} = \frac{1}{2}(1+2r)w_1 - \frac{1}{2}(1-2r)w_2 - 2rw_3$$

w_2 and w_3 affect $\frac{\partial w}{\partial r}|_1 \Rightarrow$ This results in difficulties to develop a good element based on Kirchhoff theory.

With Reissner-Mindlin theory, we independently interpolate rotations such that this problem does not arise.

For flat structures, we can superimpose the plate bending and plane stress element stiffness. For shells, curved structures, we need to develop/use curved elements, see references.

References

- [1] E. Dvorkin and K.J. Bathe. "A Continuum Mechanics Based Four-Node Shell Element for General Nonlinear Analysis." *Engineering Computations*, 1:77–88, 1984.
- [2] K.J. Bathe and E. Dvorkin. "A Four-Node Plate Bending Element Based on Mindlin/Reissner Plate Theory and a Mixed Interpolation." *International Journal for Numerical Methods in Engineering*, 21:367–383, 1985.
- [3] K.J. Bathe, A. Iosilevich and D. Chapelle. "An Evaluation of the MITC Shell Elements." *Computers & Structures*, 75:1–30, 2000.
- [4] D. Chapelle and K.J. Bathe. *The Finite Element Analysis of Shells – Fundamentals*. Springer, 2003.